

Performances selon norme ISO 9906 - Annexe A

Informations valables pour:

Eau, claire [100%] ; 4°C; 1000kg/m³; 1,57mm²/s

Caractéristiques requises

Débit	0 m³/h
Hauteur de refoulement	0 m
Power input	

Caractéristiques pompe

Pression nominale	PN 6
Poids	2,4 kg
* No condensing, no freezing	

Materials

Corps de pompe	Stainless steel / AISI 304
Rotor assembly group	Stainless steel / Composite material / Carbon
Bearing	Ceramics
Joints	EPDM Rubber
Motor housing	Aluminium
Screw ring	Aluminium
Plug	Polyamide

Caractéristiques moteur

Energy efficiency class	A		
Max Power	0,042 kW	max Strom	0,47 A
Rated voltage	230 V	Frequency	50
Classe d'isolation	F	Protection	IP 44

Dimensions mm

D	Rp 1"
DN	25
F	G 1 1/2
H	180
H1	90

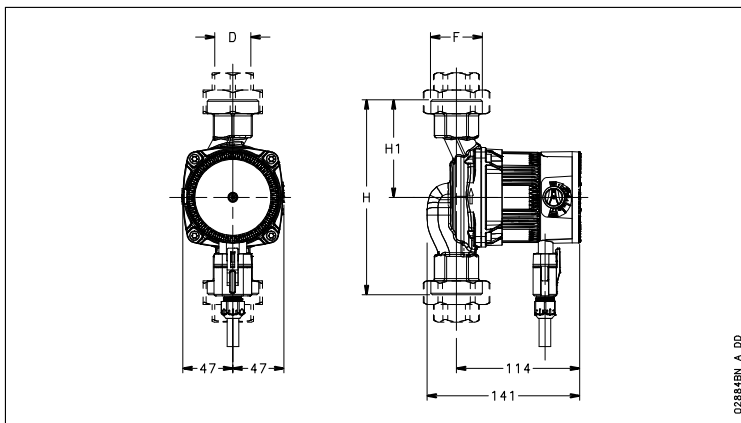

02884BN_A_DD